

YASKAWA AC Drive-V1000 Option EtherNet/IP Installation Manual

Type: SI-EN3/V

To properly use the product, read this manual thoroughly and retain for easy reference, inspection, and maintenance. Ensure the end user receives this manual.

V1000オプションユニット EtherNet/IP通信 取扱説明書

形 式 SI-EN3/V

製品を安全にお使いいただくために、本書を必ずお読みください。
また、本書をお手元に保管していただくとともに、最終的に本製品をご使用になるユーザー様のお手元に確実に届けられるよう、お取り計らい願います。

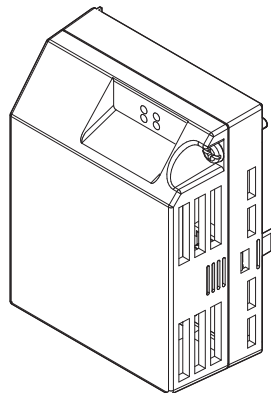

Copyright © 2012 YASKAWA ELECTRIC CORPORATION

All rights reserved. No part of this publication may be reproduced, stored in a retrieval system, or transmitted, in any form or by any means, mechanical, electronic, photocopying, recording, or otherwise, without the prior written permission of Yaskawa. No patent liability is assumed with respect to the use of the information contained herein. Moreover, because Yaskawa is constantly striving to improve its high-quality products, the information contained in this manual is subject to change without notice. Every precaution has been taken in the preparation of this manual. Yaskawa assumes no responsibility for errors or omissions. Neither is any liability assumed for damages resulting from the use of the information contained in this publication.

Table of Contents

1	PREFACE AND SAFETY	4
2	OVERVIEW	9
3	RECEIVING	11
4	OPTION COMPONENTS	12
5	INSTALLATION PROCEDURE	18
6	RELATED DRIVE PARAMETERS	33
7	CONFIGURING MESSAGING	38
8	OUTPUT ASSEMBLIES (DRIVE CONSUMES)	39
9	INPUT ASSEMBLIES (DRIVE PRODUCES)	41
10	WEB INTERFACE	43
11	TROUBLESHOOTING	47
12	EUROPEAN STANDARDS	53
13	SPECIFICATIONS	55

1 Preface and Safety

YASKAWA Electric supplies component parts for use in a wide variety of industrial applications. The selection and application of YASKAWA products remain the responsibility of the equipment designer or end user.

YASKAWA accepts no responsibility for the way its products are incorporated into the final system design. Under no circumstances should any YASKAWA product be incorporated into any product or design as the exclusive or sole safety control. Without exception, all controls should be designed to detect faults dynamically and fail safely under all circumstances. All products designed to incorporate a component part manufactured by YASKAWA must be supplied to the end user with appropriate warnings and instructions as to the safe use and operation of that part. Any warnings provided by YASKAWA must be promptly provided to the end user. YASKAWA offers an express warranty only as to the quality of its products in conforming to standards and specifications published in the manual. **NO OTHER WARRANTY, EXPRESS OR IMPLIED, IS OFFERED.** YASKAWA assumes no liability for any personal injury, property damage, losses, or claims arising from misapplication of its products.

◆ Applicable Documentation

The following manuals are available for the SI-EN3/V option:

Option Unit

	YASKAWA AC Drive -V1000 Option SI-EN3/V EtherNet/IP Installation Manual Manual No: TOBP C730600 60	Read this manual first. The installation manual is packaged with the option and contains a basic overview of wiring, settings, functions, and fault diagnoses.
	YASKAWA AC Drive -V1000 Option SI-EN3/V EtherNet/IP Technical Manual Manual No: SIEP C730600 60 (This book)	The technical manual contains detailed information. To obtain the technical manual access these sites: U.S.: http://www.yaskawa.com Europe: http://www.yaskawa.eu.com Japan: http://www.e-mechatronics.com Other areas: contact a Yaskawa representative.

Yaskawa Drive

	YASKAWA AC Drive-V1000 Quick Start Guide	To obtain instruction manuals for Yaskawa products access these sites: U.S.: http://www.yaskawa.com Europe: http://www.yaskawa.eu.com Japan: http://www.e-mechatronics.com Other areas: contact a Yaskawa representative. For questions, contact the local Yaskawa sales office or the nearest Yaskawa representative.
	YASKAWA AC Drive-V1000 Technical Manual	

◆ Terms

- Note:** Indicates supplemental information that is not related to safety messages.
- EtherNet/IP Option:** YASKAWA AC Drive -V1000 Option SI-EN3/V EtherNet/IP
- ≥ 1012:** Indicates a drive feature or function that is only available in drive software version 1012 or greater.

◆ Registered Trademarks

- EtherNet/IP is a trademark of the ODVA.
- All trademarks are the property of their respective owners.

1 Preface and Safety

◆ Supplemental Safety Information

Read and understand this manual before installing, operating, or servicing this option. The option must be installed according to this manual and local codes.

The following conventions are used to indicate safety messages in this manual. Failure to heed these messages could result in serious or possibly even fatal injury or damage to the products or to related equipment and systems.

DANGER

Indicates a hazardous situation, which, if not avoided, will cause death or serious injury.

WARNING

Indicates a hazardous situation, which, if not avoided, could cause death or serious injury.

CAUTION

Indicates a hazardous situation, which, if not avoided, could cause minor or moderate injury.

NOTICE

Indicates an equipment damage message.

■ General Safety

General Precautions

- The diagrams in this section may include options and drives without covers or safety shields to illustrate details. Be sure to reinstall covers or shields before operating any devices. The option should be used according to the instructions described in this manual.
- The diagrams in this manual are provided as examples only and may not pertain to all products covered by this manual.
- The products and specifications described in this manual or the content and presentation of the manual may be changed without notice to improve the product and/or the manual.
- Contact a Yaskawa representative or the nearest Yaskawa sales office and provide the manual number shown on the front cover to order new copies of the manual.

DANGER

Heed the safety messages in this manual.

Failure to comply will cause death or serious injury.

The operating company is responsible for any injuries or equipment damage resulting from failure to heed the warnings in this manual.

WARNING

Electrical Shock Hazard

Do not attempt to modify or alter the drive or drive circuitry in any way not explained in this manual.

Failure to comply could cause death or serious injury and will void warranty. Yaskawa is not responsible for any modification of the product made by the user. Do not modify this product.

NOTICE

Do not expose the drive or the option to halogen group disinfectants. Do not pack the drive or the option in fumigated or sterilized wooden materials. Do not sterilize the entire package after packing the product.

Failure to comply could damage electrical components in the option.

1 Preface and Safety

■ Option Unit Warning Labels

Warning information is displayed on the option unit as shown in the figure below. Follow all warnings and safety instructions when using the product.

When using the drive in an area that may require displaying warning information in Japanese or Chinese, a warning label is provided with the option. This label can be placed over the English and French warnings on the front of the option.

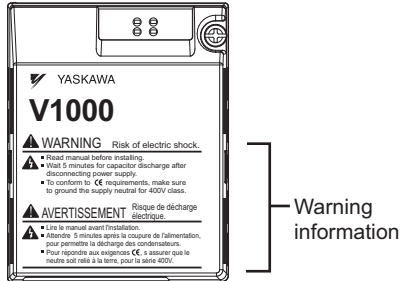

■ Warning Contents

⚠ WARNING Risk of electric shock.

- **⚡** Read manual before installing.
- Wait 5 minutes for capacitor discharge after disconnecting power supply.
- To conform to **CE** requirements, make sure to ground the supply neutral for 400V class.

⚠ AVERTISSEMENT Risque de décharge électrique.

- **⚡** Lire le manuel avant l'installation.
- Attendre 5 minutes après la coupure de l'alimentation, pour permettre la décharge des condensateurs.
- Pour répondre aux exigences **CE**, s'assurer que le neutre soit relié à la terre, pour la série 400V.

2 Overview

The option provides a communications connection between the drive and an ODVA EtherNet/IP network. The option connects the drive to an EtherNet/IP network and facilitates the exchange of data.

This manual explains the handling, installation and specifications of this product.

EtherNet/IP is a communications link to connect industrial devices (such as smart motor controllers, operator interfaces, and variable frequency drives) as well as control devices (such as programmable controllers and computers) to a network. EtherNet/IP is a simple, networking solution that reduces the cost and time to wire and install factory automation devices, while providing interchangeability of like components from multiple vendors.

EtherNet/IP is an open device network standard.

Install the option/EtherNet/IP option on a drive to perform the following functions from a EtherNet/IP master device:

- Operate the drive
- Monitor the drive operation status
- Change drive parameter settings

EtherNet/IP™
conformance tested

2 Overview

◆ Compatible Products

The option can be used with the products in [Table 1](#).

Table 1 Compatible Products

Product Series	Model(s)	Software Version <1>
V1000	CIMR-V□□A□□□□□	≥ 1012

<1> Refer to “PRG” on the drive nameplate for the software version number.

Note: For Yaskawa customers in the North or South America region:
If your product is not listed in [Table 1](#), refer to the web page below to confirm this manual is correct for your product. The web page provides a list of option manuals by product, and a direct link to download a PDF.

Scan QR code



Or refer to: <http://www.yaskawa.com/optionlookup>

3 Receiving

After receiving the option package:

1. Make sure that the option is not damaged and no parts are missing. Contact your sales outlet if the option or other parts appear damaged.

NOTICE: Do not use damaged parts to connect the drive and the option. Failure to comply could damage the drive and option.

2. Confirm that the model number on the option nameplate and the model listed in the purchase order are the same. Refer to **Figure 1** on page **12** for details. Contact the distributor where the option was purchased or the Yaskawa sales office immediately about any problems with the option.

◆ Contents and Packaging

Table 2 Option Package Contents

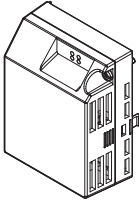
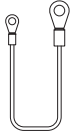
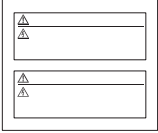
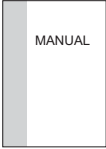
Description:	Option Unit	Ground Wire	Warning Labels	Installation Manual
—				
Quantity:	1	4	1	1

◆ Installation Tools

A Phillips screwdriver (M3, M3.5 to M6 metric or #1, #2 U.S. standard $\langle \! \langle \! \rangle \! \rangle$) is required to install the option.

$\langle \! \langle \! \rangle \! \rangle$ Screw sizes vary by drive capacity. Select a screwdriver appropriate for the drive capacity.

Note: Tools required to prepare the option cables for wiring are not listed in this manual.

4 Option Components

◆ SI-EN3/V Option

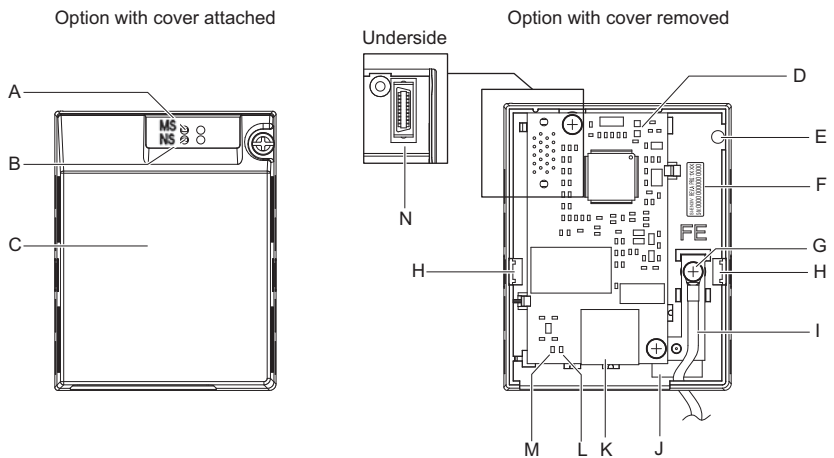

- | | |
|---|---|
| A – LED (MS) <1> | H – Mounting tabs |
| B – LED (NS) <1> | I – Ground wire <2> |
| C – Option cover | J – Pass-through hole for wire |
| D – EtherNet/IP PCB | K – Communication connector CN1 (RJ45) |
| E – Screw hole (attaching option cover) | L – LED (LINK/ACT) <1> |
| F – Nameplate | M – LED (10/100) <1> |
| G – Functional earth cable connection (FE) | N – Option connector |

<1> Refer to [Option LED Display on page 16](#) for details on the LEDs.

<2> A selection of ground wires are packaged loose in the option shipping package. Connect the appropriate ground wire based on drive model during installation.

Figure 1 Option Unit Components

◆ Dimensions

The installed option adds 27 mm (1.06 in.) to the total depth of the drive.

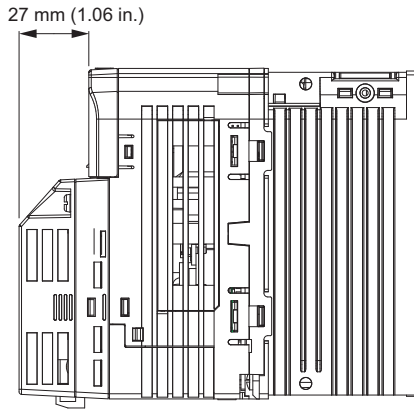

Figure 2 Dimensions

4 Option Components

◆ Communication Connector CN1

The communication connector on the option is a modular RJ45 female connector designated CN1.

CN1 is the connection point for a customer-supplied male Ethernet network communication cable.

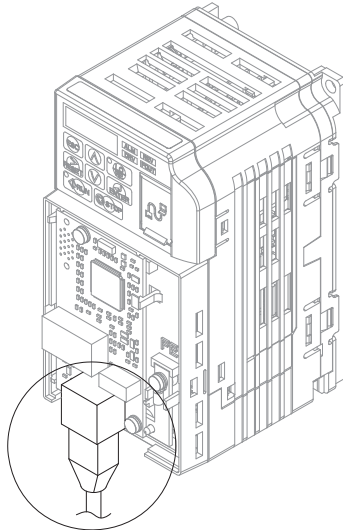
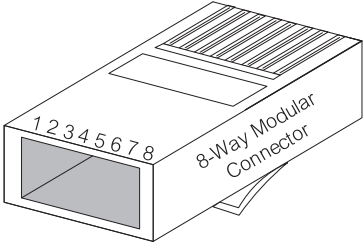

Figure 3 Communication connector CN1 (RJ45)

Table 3 Male 8-way Ethernet Modular Connector (Customer Supplied)

Male EtherNet 8-Way Modular Connector	Pin	Description
	1 (Pair 2)	Transmit data (TXD) +
	2 (Pair 2)	Transmit data (TXD) -
	3 (Pair 3)	Receive data (RXD) +
	4 (Pair 1)	Not used </>
	5 (Pair 1)	Not used </>
	6 (Pair 3)	Receive data (RXD) -
	7 (Pair 4)	Not used </>
	8 (Pair 4)	Not used </>

</> Not used for 10 Mbps and 100 Mbps networks.

4 Option Components

◆ Option LED Display

The option has four LEDs:

Bi-color Status LEDs:

- Module status (MS) red/green
- Network status (NS) red/green

Green Ethernet LEDs:

- Network speed-10/100 (MS) green
- Link status and network activity-Link/Act (NS) red/green

The operational states of the option LEDs after the power-up diagnostic LED sequence is completed are described in [Table 4](#). Wait at least 2 seconds for the power-up diagnostic process to complete before verifying the states of the LEDs.

Table 4 Option LED States

LED Name	Indication		Operating Status	Description
	Color	Status		
MS	–	OFF	Power supply OFF	Power is not being supplied to the drive
	Green	ON	Option operating	The option is operating normally
	Green	Flashing	Option initializing	The option is configuring an IP address
	Red	ON	Fatal error occurred	The option has detected a fatal (unrecoverable) error
	Red	Flashing	Non-fatal error occurred	The option has detected a non-fatal (recoverable) error
	Green/Red	Flashing	Option self-test	The option is in self-test mode
NS	–	OFF	Offline or Power supply OFF	–
	Green	ON	Online communications established	The option is online and has established connections
	Green	Flashing	Online communications not established	The option is online without an established connection
	Red	ON	Communications error (fatal)	The option detected a duplicate IP address
	Red	Flashing	Communications time-out (non-fatal)	A communications time-out occurred
	Green/Red	Flashing	Option self-test	The option is in self-test mode
10/100 </>	Green	OFF	10 Mbps is established	–
	Green	ON	100 Mbps is established	
LINK/ ACT </>	Green	OFF	Link is not established	
	Green	ON	Link is established	
	Green	Flashing	Link is established and there is network activity	

<1> Remove the cover for the option unit to check the status of the LED. Be careful not to touch the main circuit terminals or the control board in the drive.

■ Power-Up Diagnostics

An LED test is performed each time the drive is powered up. The initial boot sequence may take several seconds. After the LEDs have completed the diagnostic LED sequence, the option is successfully initialized. The LEDs then assume operational conditions as shown in [Table 4](#).

Table 5 Power-Up Diagnostic LED Sequence

Sequence	Module Status (MS)	Network Status (NS)	Time (ms)
1	Green	OFF	250
2	Red	OFF	250
3	Green	OFF	–
4	Green	Green	250
5	Green	Red	250
6	Green	OFF	–

5 Installation Procedure

◆ Section Safety

DANGER

Electrical Shock Hazard

Do not inspect, connect, or disconnect any wiring while the drive is energized.

Failure to comply will cause death or serious injury.

Disconnect all power to the drive, wait at least five minutes after all indicators are off, measure the DC bus voltage to confirm safe level, and check for unsafe voltages before servicing to prevent electric shock. The internal capacitor remains charged even after the power supply is turned off. The charge indicator LED will extinguish when the DC bus voltage is below 50 Vdc.

WARNING

Electrical Shock Hazard

Do not remove option board cover while the power is on.

Failure to comply could result in death or serious injury.

The diagrams in this section may include option units and drives without covers or safety shields to show details. Be sure to reinstall covers or shields before operating any devices. The option should be used according to the instructions described in this manual.

Do not allow unqualified personnel to perform work on the drive or option.

Failure to comply could cause death or serious injury.

Only authorized personnel familiar with installation, adjustment, and maintenance of AC drives and options may perform work.



WARNING

Do not use damaged wires, stress the wiring, or damage the wire insulation.

Failure to comply could cause death or serious injury.

Fire Hazard

Tighten all terminal screws to the specified tightening torque.

Loose or overtightened connections could cause erroneous operation and damage to the terminal block or start a fire and cause death or serious injury.

NOTICE

Damage to Equipment

Observe proper electrostatic discharge (ESD) procedures when handling the option, drive, and circuit boards.

Failure to comply could cause ESD damage to circuitry.

Never connect or disconnect the motor from the drive while the drive is outputting voltage.

Improper equipment sequencing could damage the drive.

Do not connect or operate any equipment with visible damage or missing parts.

Failure to comply could further damage the equipment.

Do not use unshielded wire for control wiring.

Failure to comply may cause electrical interference resulting in poor system performance. Use shielded, twisted-pair wires and ground the shield to the ground terminal of the drive.

Properly connect all pins and connectors on the option and drive.

Failure to comply could prevent proper operation and damage equipment.

Confirm that all connections are correct after installing the option and connecting peripheral devices.

Failure to comply could damage the option.

5 Installation Procedure

◆ Prior to Installing the Option

Prior to installing the option, wire the drive, make necessary connections to the drive terminals, and verify that the drive functions normally without the option installed. Refer to the Quick Start Guide packaged with the drive for information on wiring and connecting the drive.

◆ Installing the Option

Refer to the instructions below to install the option.

DANGER! *Electrical Shock Hazard. Do not connect or disconnect wiring while the power is on. Failure to comply could result in death or serious injury. Before installing the option, disconnect all power to the drive. The internal capacitor remains charged even after the power supply is turned off. The charge indicator LED will extinguish when the DC bus voltage is below 50 Vdc. To prevent electric shock, wait at least five minutes after all indicators are off and measure the DC bus voltage level to confirm safe level.*

1. Shut off power to the drive, wait at least five minutes after confirming the DC bus voltage is safe, then loosen the screw that fastens the front cover in place and remove the front cover. This drive front cover will be replaced by the option cover. Cover removal varies depending on drive size.

NOTICE: *Damage to Equipment. Observe proper electrostatic discharge procedures (ESD) when handling the option, drive, and circuit boards. Failure to comply may result in ESD damage to circuitry.*

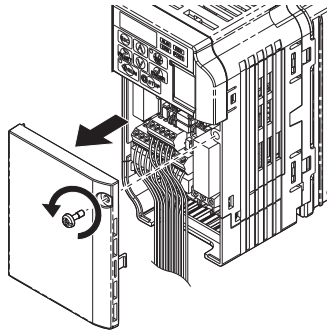

Figure 4 Remove Front Cover

2. The remaining installation steps differ based on drive model. Find the drive model number on the drive nameplate and refer to the step indicated in [Table 6](#) based on your model number.

Table 6 Installation Steps Based on Drive Model

Enclosure Type	Drive Model	Proceed to Step	Page
IP20/Open-Chassis	CIMR-V□□A□□□□B	3.	21
IP20/NEMA Type 1 <F>	CIMR-V□□A□□□□F	6.	23

<1> Installing the option on an IP20/NEMA Type 1 enclosure drive voids NEMA Type 1 protection while maintaining IP20 conformity.

- For IP20/Open-Chassis models CIMR-V□□A□□□□B, Remove the bottom cover of the drive by applying pressure to the tabs on each side of the bottom cover. Pull the bottom cover away from the drive while pushing in on the tabs to release the cover from the drive. Refer to [Figure 5](#) for details. Refer to [Figure 6](#) for drive models CIMR-V□□BA0006B to BA0018B, 2A0008B to 2A0069B, and 4A0001B to 4A0038B, which require removing the terminal cover prior to removing the bottom cover.

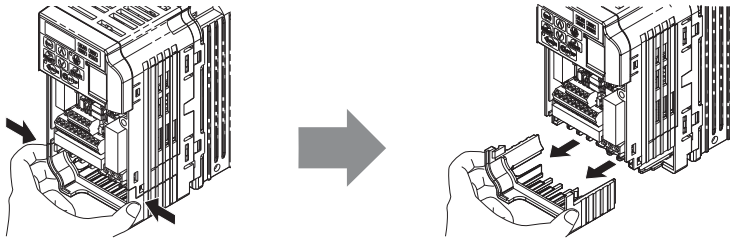

Figure 5 Remove the Bottom Cover on an IP20/Open-Chassis Drive (Models CIMR-V□□BA0001B to BA0003B and 2A0001B to 2A0006B)

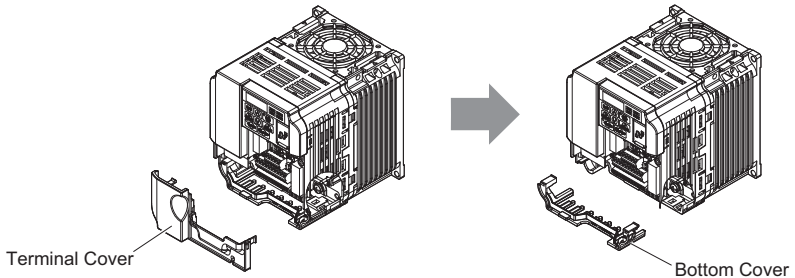

Figure 6 Remove the Terminal Cover and Bottom Cover on an IP20/Open-Chassis Drive (Models CIMR-V□□BA0006B to BA0018B; 2A0008B to 2A0069B; 4A0001B to 4A0038B)

5 Installation Procedure

- On IP20/Open-Chassis models, connect the drive side of the ground wire to the drive ground terminal.

Note: The four different ground wires packaged with the option connect the option to different drive models. Select the proper ground wire depending on drive size. Refer to [Table 7](#) for ground wire selection by drive model.

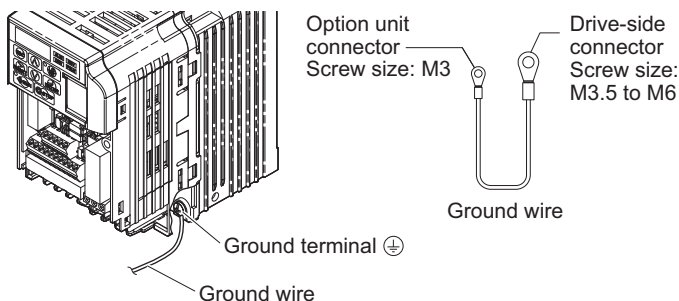

Figure 7 Connect the Ground Wire on an IP20/Open-Chassis Drive

Table 7 Ground Wire Selection

Ground Wire Length (mm/in)	Drive Model CIMR-V□		
	Single-Phase 200 V Class	Three-Phase 200 V Class	Three-Phase 400 V Class
150/5.9	BA0001 BA0002 BA0003	2A0001 2A0002 2A0004 2A0006	—
200/7.9	BA0006 BA0010 BA0012 BA0018	2A0010 2A0012 2A0020	4A0001 4A0002 4A0004 4A0005 4A0007 4A0009 4A0011
250/9.8	—	2A0030 2A0040	4A0018 4A0023
400/15.7	—	2A0056 2A0069	4A0031 4A0038

5. For IP20/Open-Chassis models, go to Step 9. on page 26.
6. For IP20/NEMA Type 1 enclosure models CIMR-V□□A□□□□F, loosen the screw on the front of the NEMA Type 1 terminal cover and remove it from the drive. Refer to **Figure 8** for details.
Refer to **Figure 9** for drive models CIMR-V□BA0006F to BA0018F, 2A0010F to 2A0069F, and 4A0001F to 4A0038F, which require removing the plastic terminal cover prior to removing the NEMA Type 1 terminal cover.

Note: Installing the option on an IP20/NEMA Type 1 enclosure drive voids NEMA Type 1 protection while maintaining IP20 conformity.

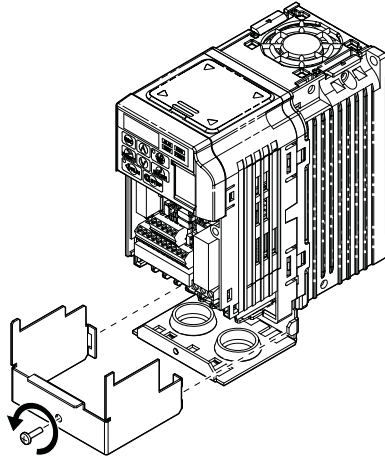

**Figure 8 Remove the NEMA Type 1 Terminal Cover
(CIMR-V□BA0001F to BA0003F, 2A0001F to 2A0006F)**

5 Installation Procedure

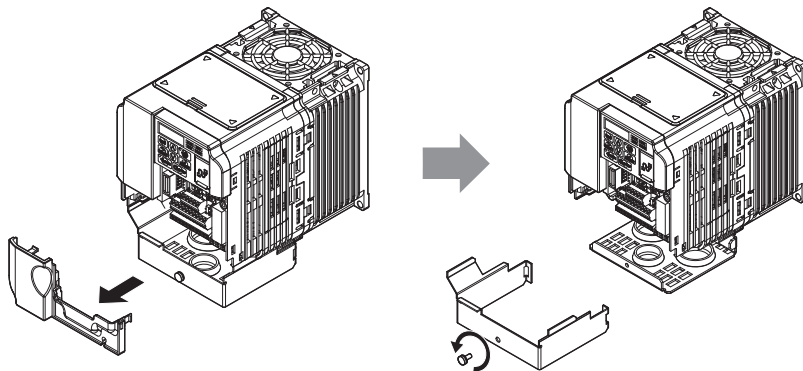

Figure 9 Remove the Terminal Cover on an IP20/NEMA Type 1 Drive (Models CIMR-V□BA0006F to BA0018F; 2A0008F to 2A0069F; 4A0001F to 4A0038F)

7. For models CIMR-V□BA0001F to BA0003F, 2A0001F to 2A0006F, loosen the screws attaching the NEMA Type 1 conduit bracket to the drive to remove the NEMA Type 1 conduit bracket.

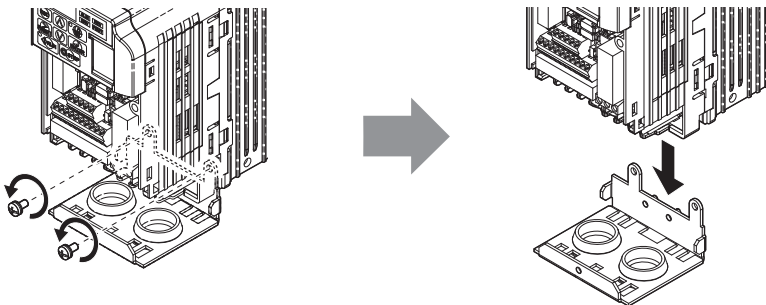

Figure 10 Remove the NEMA Type 1 Conduit Bracket

8. On NEMA Type 1 enclosure models (CIMR-V□BA0001F to BA0003F, 2A0001F to 2A0006F), the screw for the drive ground terminal also acts as one of the screws that attaches the NEMA Type 1 conduit bracket to the drive. Reattach the NEMA Type 1 conduit bracket according to [Figure 11](#) and connect the drive-side of the ground wire to the drive ground terminal.

Note: The four different ground wires packaged with the option connect the option to different drive models. Select the proper ground wire depending on drive size. Refer to [Table 7](#) on page [22](#) for ground wire selection by drive model.

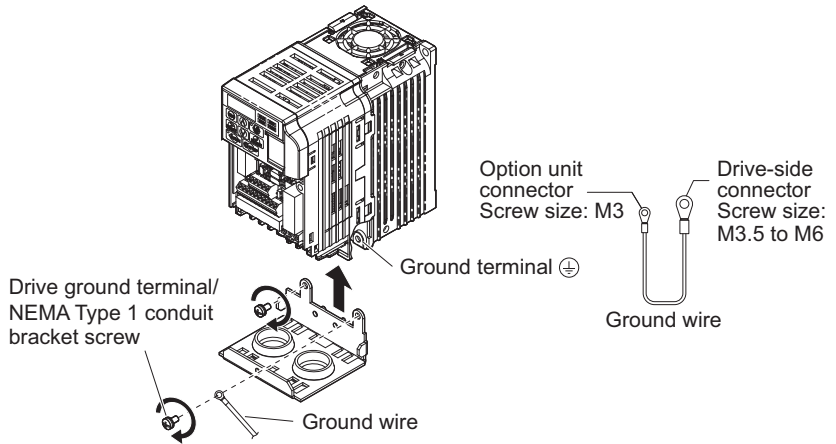

Figure 11 Reattach the NEMA Type 1 Conduit Bracket and Connect the Ground Wire for models CIMR-V□BA0001F to BA0003F, 2A0001F to 2A0006F

5 Installation Procedure

9. Reattach the bottom cover. Keep the ground wire inside of the bottom cover when reattaching.

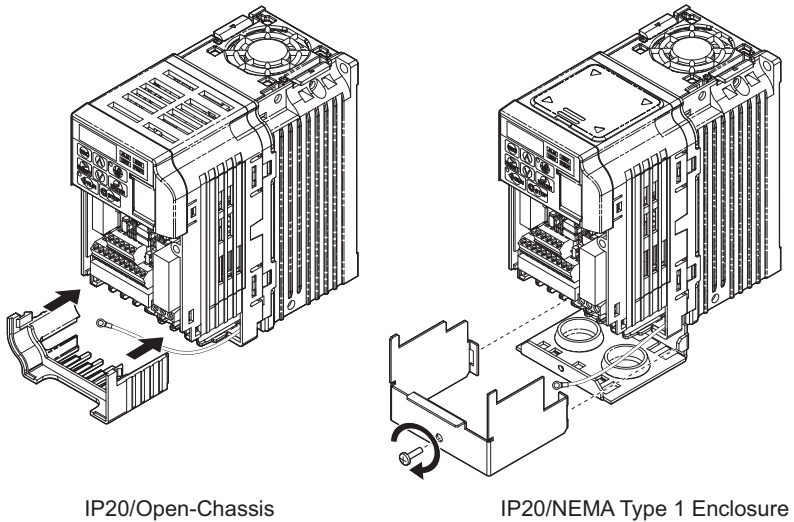

Figure 12 Reattach the Bottom Cover

10. On models CIMR-V□BA0006□ to BA0018□, 2A0008□ to 2A0069□, and 4A0001□ to 4A0038□, reattach the terminal cover. Refer to [Figure 13](#) and [Figure 14](#) for drive models CIMR-V□BA0006□ to BA0018□, 2A0008□ to 2A0020□, and 4A0001□ to 4A0011□, which require routing the ground wire through the provided notch when reinstalling the terminal cover.

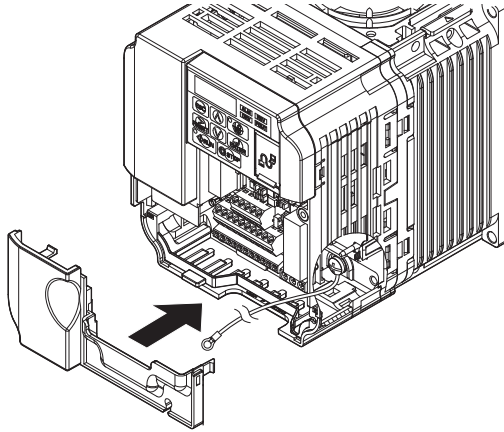

Figure 13 Reattach the Terminal Cover
(Models CIMR-V□BA0006□ to BA0018□; 2A0008□ to 2A0069□; 4A0001□ to 4A0038□)

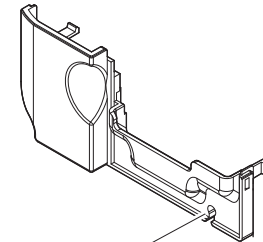
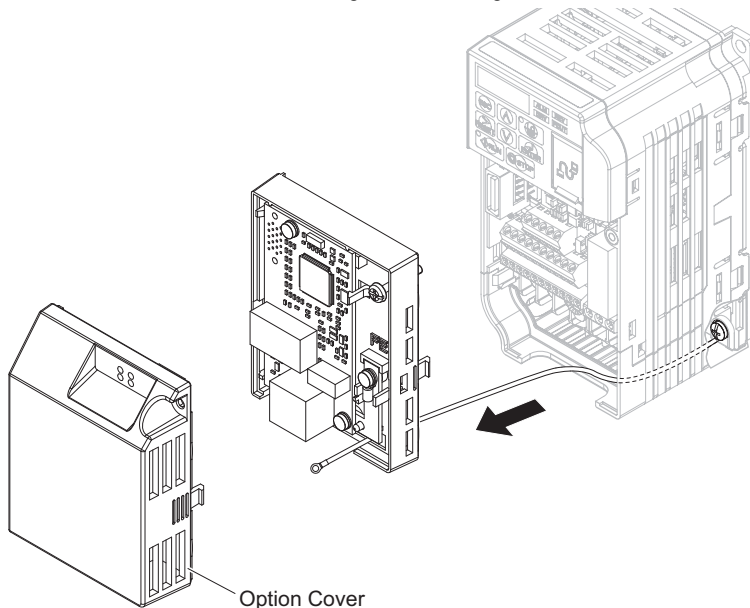

Figure 14 Terminal Cover Ground Wire Notch
(Models CIMR-V□BA0006□ to BA0018□; 2A0008□ to 2A0020□; 4A0001□ to 4A0011□)

5 Installation Procedure

11. Remove the option cover and pass the ground wire through the inside of the drive bottom cover and into the through-hole for the ground wire at the front of the option.



Option Cover

Figure 15 Ground Wire Routing

12. Attach the option to the drive. Properly seat the tabs on the left and right sides of the option to the drive case.

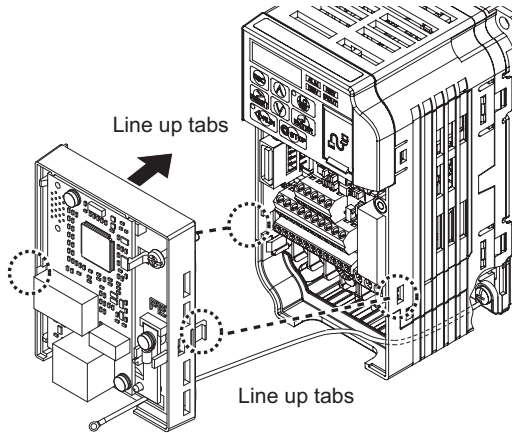

Figure 16 Connect the Option

13. Connect the ground wire at the option ground terminal. Tighten the screw to 0.5 to 0.6 N·m or (4.4 to 5.3 in lbs) using an M3 Phillips screwdriver.

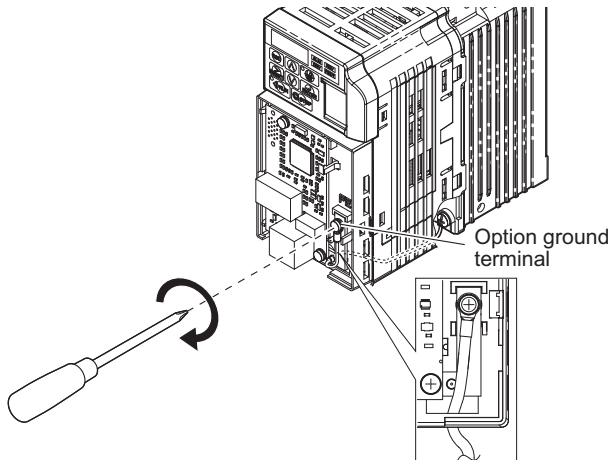

Figure 17 Connect the Ground Wire to the Option

5 Installation Procedure

14. To connect the option to a network, firmly connect RJ45 8-pin Shielded Twisted Pair Cat5e cable(s) into the modular connector port.

Note: Do not connect or disconnect the communication cable while the drive is powered up or while the drive is in operation. Failure to comply may cause a static discharge, which will cause the option card to stop working properly. Cycle power on the drive and option card to reestablish functionality.

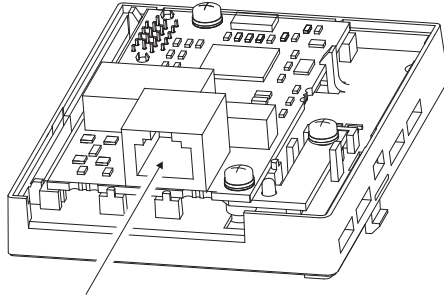

Figure 18 Communication Cable Port

IGMP Snooping

Switches implementing IGMP Snooping are strongly recommended. When IGMP Snooping is used, devices will only receive the multicast packets in which they are interested.

Communication Cable Specifications

Only use cables recommended for EtherNet/Industrial Protocol (EtherNet/IP™). Using a cable not specifically recommended may cause the option or drive to malfunction.

The use of Cat5e or equivalent Shielded Twisted Pair (STP) cable is recommended.

Refer to the ODVA website for more information on network cabling (<http://www.odva.org>).

Connection Diagram

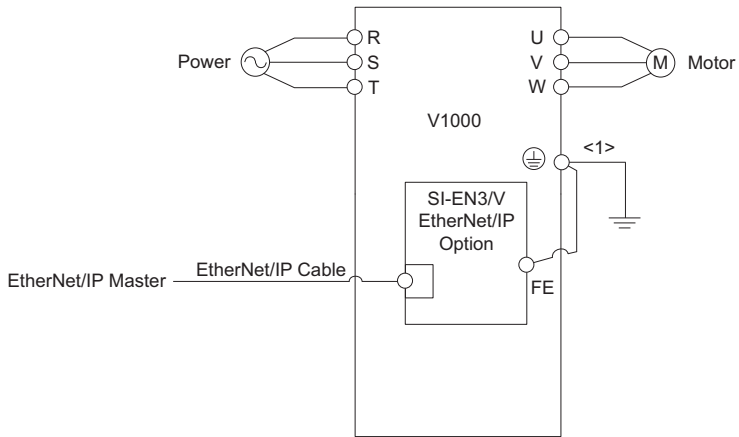

<1> The ground wire provided in the option shipping package must be connected during installation.

Figure 19 Wiring Diagram

5 Installation Procedure

15. Attach the option cover by aligning the tabs with the mounting holes, seat the front cover into place, and tighten the screw on the front.

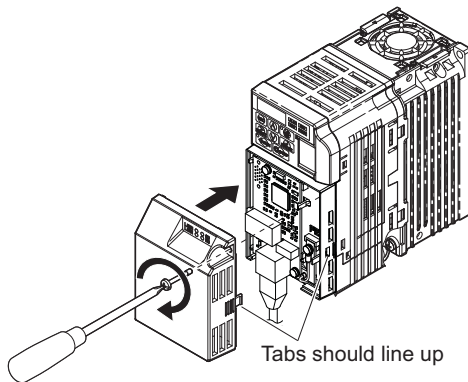

Figure 20 Attach the Option Cover

Note: Take proper precautions when wiring the option so that the front covers will easily fit back onto the drive. Make sure no cables are pinched between the front covers and the drive when replacing the covers.

16. Set drive parameters in Table 6 for proper option performance.

◆ EDS Files

For easy network implementation of drives equipped with the option, an EDS file can be obtained from:

U.S.: <http://www.yaskawa.com>

Europe: <http://www.yaskawa.eu.com>

Japan: <http://www.e-mechatronics.com>

Other areas: Check the back cover of these manuals.

Note: Download the EDS file for SI-EN3/V option. The SI-EN3/V will not function as a slave in the network without the appropriate EDS file.

6 Related Drive Parameters

The parameters in **Table 8** set the drive for operation with the option. Confirm proper setting of all parameters in **Table 8** before starting network communications. Refer to the manual packaged with the drive for details on setting parameters.

Table 8 Related Parameter Settings

No. (Addr. Hex)	Name	Description	Values
b1-01 (180) </>	Reference 1 Source	Selects the input method for frequency reference. 0: Keypad 1: Analog Input 2: Memobus/Modbus Communications 3: Option PCB 4: Pulse Train Input	Default: 1 Range: 0 to 4 (Set to 3)
b1-02 (181) </>	Run Command 1 Source	Selects the input method for the Run command. 0: Keypad 1: Digital Input 2: Memobus/Modbus Communications 3: Option PCB	Default: 1 Range: 0 to 3 (Set to 3)
F6-01 (3A2)	Communication Error Selection	Selects drive response when a bUS error is detected during communications with the option. 0: Ramp to Stop 1: Coast to Stop 2: Fast Stop (Use C1-09) 3: Alarm Only <?> 4: Alarm - Run at d1-04 5: Alarm - Ramp to Stop	Default: 1 Range: 0 to 5 <?>
F6-02 (3A3)	Comm External Fault (EF0) Detect	Selects the condition for external fault detection (EF0). 0: Always detected 1: Detection during run only	Default: 0 Range: 0, 1
F6-03 (3A4)	Comm External Fault (EF0) Select	Selects drive response for external fault input (EF0) detection during option communications. 0: Ramp to Stop 1: Coast to Stop 2: Fast Stop (Use C1-09) 3: Alarm Only <?>	Default: 1 Range: 0 to 3
F6-07 (3A8)	MultiStep Ref Priority Select	0: MultiStep References Disabled 1: MultiStep References Enabled	Default: 1 Range: 0, 1
F6-08 (36A)	Comm Parameter Reset @Initialize	Selects whether communication-related parameters F6-□□ and F7-□□ are set back to original default values when the drive is initialized using parameter A1-03. 0: No Reset - Parameters retained 1: Reset - Back to factory default Note: The setting value is not changed even when F6-08 is set to 1 and the drive is initialized using A1-03.	Default: 0 Range: 0, 1

6 Related Drive Parameters

No. (Addr. Hex)	Name	Description	Values
F6-15 (B5B)	Comm. Option Parameter Upgrade Selection	Selects whether F6-□□/□□/□□ communication-related parameters changed are enabled. 0: Enabled by Cycling the Power 1: Enabled F6-□□□/□□□ 2: Disabled F6-□□□/□□□ Note: F6-15 is reset to 0 after setting to 1 or 2.	Default: 0 Range: 0 to 2
F7-01 (3E5) <><> <>	IP Address 1	Sets the static/fixed IP address. Parameter F7-01 sets the most significant octet.	Default: 192 Min: 0 Max: 255
F7-02 (3E6) <><> <>	IP Address 2	Sets the static/fixed IP address. Parameter F7-02 sets the second most significant octet.	Default: 168 Min: 0 Max: 255
F7-03 (3E7) <><> <>	IP Address 3	Sets the static/fixed IP address. Parameter F7-03 sets the third most significant octet.	Default: 1 Min: 0 Max: 255
F7-04 (3E8) <><> <>	IP Address 4	Sets the static/fixed IP address. Parameter F7-04 sets the fourth most significant octet.	Default: 20 Min: 0 Max: 255
F7-05 (3E9) <>	Subnet Mask 1	Sets the static/fixed Subnet Mask. Parameter F7-05 sets the most significant octet.	Default: 255 Min: 0 Max: 255
F7-06 (3EA) <>	Subnet Mask 2	Sets the static/fixed Subnet Mask. Parameter F7-06 sets the second most significant octet.	Default: 255 Min: 0 Max: 255
F7-07 (3EB) <>	Subnet Mask 3	Sets the static/fixed Subnet Mask. Parameter F7-07 sets the third most significant octet.	Default: 255 Min: 0 Max: 255
F7-08 (3EC) <>	Subnet Mask 4	Sets the static/fixed Subnet Mask. Parameter F7-08 sets the fourth most significant octet.	Default: 0 Min: 0 Max: 255
F7-09 (3ED) <>	Gateway Address 1	Sets the static/fixed Gateway address. Parameter F7-09 sets the most significant octet.	Default: 192 Min: 0 Max: 255
F7-10 (3EE) <>	Gateway Address 2	Sets the static/fixed Gateway address. Parameter F7-10 sets the second most significant octet.	Default: 168 Min: 0 Max: 255

6 Related Drive Parameters

No. (Addr. Hex)	Name	Description	Values
F7-11 (3EF) <5>	Gateway Address 3	Sets the static/fixed Gateway address. Parameter F7-11 sets the third most significant octet.	Default: 1 Min: 0 Max: 255
F7-12 (3F0) <5>	Gateway Address 4	Sets the static/fixed Gateway address. Parameter F7-12 sets the fourth most significant octet.	Default: 1 Min: 0 Max: 255
F7-13 (3F1)	Address Mode at Startup	Selects how the option address is set. 0: Static 1: BOOTP 2: DHCP	Default: 2 Range: 0 to 2
F7-14 (3F2)	Duplex Mode Selection	Selects duplex mode setting. 0: Auto/Auto 1: Half/Half 2: Full/Full 3: Half/Auto 4: Half/Full 5: Auto/Half 6: Auto/Full 7: Full/Half 8: Full/Auto	Default: <6> Range: 0 to 8
F7-15 (3F3) <7>	Communication Speed Selection	Sets the communication speed 0: 10 Mbps (Available only with drive software version PRG: 1012 to 1015) 10: 10 Mbps 100: 100 Mbps	Default: <8> Range: <8>
F7-17 (3F5)	EtherNet/IP Speed Scaling Factor	Sets the scaling factor for the speed monitor in EtherNet/IP Class ID 2AH Object.	Default: 0 Min.: -15 Max.: 15
F7-18 (3F6)	EtherNet/IP Current Scaling Factor	Sets the scaling factor for the output current monitor in EtherNet/IP Class ID 2AH Object.	Default: 0 Min.: -15 Max.: 15
F7-19 (3F7)	EtherNet/IP Torque Scaling Factor	Sets the scaling factor for the torque monitor in EtherNet/IP Class ID 2AH Object.	Default: 0 Min.: -15 Max.: 15
F7-20 (3F8)	EtherNet/IP Power Scaling Factor	Sets the scaling factor for the power monitor in EtherNet/IP Class ID 2AH Object.	Default: 0 Min.: -15 Max.: 15
F7-21 (3F9)	EtherNet/IP Voltage Scaling Factor	Sets the scaling factor for the voltage monitor in EtherNet/IP Class ID 2AH Object.	Default: 0 Min.: -15 Max.: 15
F7-22 (3FA)	EtherNet/IP Time Scaling	Sets the scaling factor for the time monitor in EtherNet/IP Class ID 2AH Object.	Default: 0 Min.: -15 Max.: 15

6 Related Drive Parameters

No. (Addr. Hex)	Name	Description	Values
F7-23 to F7-32 (3FB to 404)	Dynamic Output Assembly Parameters	Parameters used in Output Assembly 116. Each parameter contains a MEMOBUS/Modbus address. The value received for Output Assembly 116 will be written to this corresponding MEMOBUS/Modbus address. A MEMOBUS/Modbus address value of 0 means that the value received for Output Assembly 116 will not be written to any MEMOBUS/Modbus register.	Default: 0
F7-33 to F7-42 (405 to 40E)	Dynamic Input Assembly Parameters	Parameters used in Input Assembly 166. Each parameter contains a MEMOBUS/Modbus address. The value sent for Input Assembly 166 will be read from this corresponding MEMOBUS/Modbus address. A MEMOBUS/Modbus address value of 0 means that the value sent for Input Assembly 166 is not defined by the user, therefore the option default register value will be returned. <i>Refer to Input Assemblies (Drive Produces) on page 41</i> for definitions of the default MEMOBUS/Modbus registers.	Default: 0

- <1> Set b1-02 = 3 to start and stop the drive with the EtherNet/IP master device using serial communications.
Set b1-01 = 3 to control the frequency reference of the drive via the master device.
- <2> Setting this parameter to 3 will cause the drive to continue operation after detecting a fault. Take proper measures such as installing an emergency stop switch when using setting 3.
- <3> Cycle power for setting changes to take effect.
- <4> If F7-13 is set to 0, then all IP Addresses (F7-01 to F7-04) must be unique.
- <5> Set F7-01 to F7-12 when F7-13 is set to 0.
- <6> Default setting differs by drive software version.
1012 to 1015: 0
≥ 1016: 1
- <7> Set F7-15 when F7-14 is set to 0 or 2.
- <8> The setting values differ by drive software version.
1012 to 1015
Default: 0
Range: 0, 10, 100
≥ 1016
Default: 10
Range: 10, 100

Table 9 Option Monitors

No.	Name	Description	Range
U6-80 to U6-83	OPT IP ADR 1 to 4	Displays IP Address currently available; <ul style="list-style-type: none"> • U6 -80: First octet • U6 -81: Second octet • U6 -82: Third octet • U6 -83: Forth octet 	0 to 255
U6-84 to U6-87	Online Subnet 1 to 4	Displays subnet currently available; <ul style="list-style-type: none"> • U6 -84: First octet • U6 -85: Second octet • U6 -86: Third octet • U6 -87: Forth octet 	0 to 255
U6-88 to U6-91	Online Gateway	Displays gateway currently available; <ul style="list-style-type: none"> • U6 -88: First octet • U6 -89: Second octet • U6 -90: Third octet • U6 -91: Forth octet 	0 to 255
U6-92	Online Speed	Displays CN1 Port 1 link speed currently available.	10: 10 Mbps 100: 100 Mbps
U6-93	Online Duplex	Displays CN1 Port 1 duplex setting currently available.	0: Half, 1: Full
U6-98	First Fault	Displays first option fault. Refer to <i>Option Fault Monitors U6-98 and U6-99 on page 52</i> for details.	-
U6-99	Current Fault	Displays current option fault. Refer to <i>Option Fault Monitors U6-98 and U6-99 on page 52</i> for details.	-

7 Configuring Messaging

7 Configuring Messaging

This section provides information on methods used to control the drive with the option installed.

◆ Drive Polled Configuration

The assemblies in [Table 10](#) are available for polled I/O:

Table 10 Supported Polled I/O Assemblies

Assembly Number (Hex)	Description	Type	Bytes	Page
20 (14)	Basic Speed Control Output	Output	4	39
21 (15)	Extended Speed Control Output	Output	4	40
22 (16)	Speed and Torque Control Output	Output	6	–
23 (17)	Extended Speed and Torque Control Output	Output	6	–
70 (46)	Basic Speed Control Input	Input	4	41
71 (47)	Extended Speed Control Input	Input	4	42
72 (48)	Speed and Torque Control Input	Input	6	–
73 (49)	Extended Speed and Torque Control Input	Input	6	–
100 (64)	(Vendor Specific Yaskawa Electric (YE) Assy)-MEMOBUS/Modbus Message Output	Output	5	–
101 (65)	(Vendor Specific Yaskawa Electric (YE) Assy)-Speed/Torque Control Output	Output	8	–
115 (73)	(Vendor Specific Yaskawa Electric (YE) Assy)-Extended Speed/Torque Control Output	Output	40	–
116 (74)	(Vendor Specific Yaskawa Electric (YE) Assy)-High Speed/Torque Control Output	Output	44	–
150 (96)	(Vendor Specific Yaskawa Electric (YE) Assy)-MEMOBUS/Modbus Message Input	Input	5	–
151 (97)	(Vendor Specific Yaskawa Electric (YE) Assy)-Speed/Torque Status Input	Input	8	–
155 (9B)	(Vendor Specific Yaskawa Electric (YE) Assy)- Extended Speed/ Torque Status Input	Input	40	–
166 (A6)	(Vendor Specific Yaskawa Electric (YE) Assy)-High Speed/Torque Status Input	Input	44	–

8 Output Assemblies (Drive Consumes)

Note: The convention in this manual is from the PLC perspective. As such, an assembly is called an “Output Assembly” when outputted from the PLC and received by this node. This section details “Output Assemblies” that are “Consumed” by this drive.

◆ Basic Speed Control Output - 20 (0x14)

Output Instance	Word	Byte	Bit 7	Bit 6	Bit 5	Bit 4	Bit 3	Bit 2	Bit 1	Bit 0	
20	0	0	–	–	–	–	–	Fault Reset	–	Run Fwd	
		1	–								
	1	2	Speed Reference (Low Byte)								
		3	Speed Reference (High Byte)								

Name	Description
Run Fwd	Forward Run Command 0: Stop 1: Forward Run
Fault Reset	Fault Reset (0 to 1 transition: Fault Reset)
Speed Reference	Speed Command Sets drive speed reference. Speed reference data: Frequency reference/2 ^{SS} (SS: Speed scale) Setting range: 0 to 0xFFFF Example: setting a reference of 4096 with a speed scale of 2: Speed reference data = 4096/2 ² = 1024 = 0x0400 Hex or 10.24 Hz Unit depends on o1-03.

8 Output Assemblies (Drive Consumes)

◆ Extended Speed Control Output - 21 (0x15)

Output Instance	Word	Byte	Bit 7	Bit 6	Bit 5	Bit 4	Bit 3	Bit 2	Bit 1	Bit 0	
21	0	0	–	NetRef	NetCtrl	–	–	Fault Reset	Run Rev	Run Fwd	
		1	–								
	1	2	Speed Reference (Low Byte)								
		3	Speed Reference (High Byte)								

Name	Description
Run Fwd	Forward Run Command 0: Stop 1: Forward Run
Run Rev	Reverse Run Command 0: Stop 1: Reverse Run
Fault Reset	Fault Reset (0 to 1 transition: Fault Reset)
NetCtrl	Run command from Network 0: Depends on b1-02 1: Enables the run command from network
NetRef	Speed reference from Network 0: Depends on b1-01 1: Enables the speed reference from network
Speed Reference	Speed Command Sets drive speed reference. Speed reference data: Frequency reference/2 ^{SS} (SS: Speed scale) Setting range: 0 to 0xFFFF For example, when setting a reference of 4096 with a speed scale of 2: Speed reference data = 4096/2 ² = 1024 = 0x0400 Unit depends on o1-03.

9 Input Assemblies (Drive Produces)

Note: The convention in this manual is from the PLC perspective. An “Input Assembly” is outputted from this node and read by the PLC. This section details “Input Assemblies” that are “Produced” by this drive.

◆ Basic Speed Control Input - 70 (0x46)

Input Instance	Word	Byte	Bit 7	Bit 6	Bit 5	Bit 4	Bit 3	Bit 2	Bit 1	Bit 0	
70	0	0	–	–	–	–	–	Running 1 (FWD)	–	Faulted	
		1	–								
	1	2	Speed Actual (Low Byte)								
		3	Speed Actual (High Byte)								

Parameter	Data
Faulted	Faulted 0: No Faults Occurred 1: Fault Occurred
Running 1 (FWD)	Forward Running 0: Stop or Reverse Running 1: Forward Running
Speed Actual	Actual Drive Speed Monitors drive output frequency. Speed actual data: Output frequency x 2 ^{SS} (SS: Speed scale) Range: 0 to 0xFFFF For example, when output frequency of 1024 with a speed scale of 2: Speed actual data = 1024 x 2 ² = 4096 = 0x1000 Unit depends on o1-03.

9 Input Assemblies (Drive Produces)

◆ Extended Speed Control Input - 71 (0x47)

Input Instance	Word	Byte	Bit 7	Bit 6	Bit 5	Bit 4	Bit 3	Bit 2	Bit 1	Bit 0	
71	0	0	At Speed	Ref from Net	Ctrl from Net	Ready	Running 2 (REV)	Running 1 (FWD)	Warning	Faulted	
		1	Drive State								
	1	2	Speed Actual (Low Byte)								
		3	Speed Actual (High Byte)								

Name	Description
Faulted	Faulted 0: No Faults Occurred 1: Fault Occurred
Warning	Warning 0: No Warning Occurred 1: Warning Occurred
Running 1 (FWD)	Forward Running 0: Stop or Reverse Running 1: Forward Running
Running 2 (REV)	Reverse Running 0: Stop or Forward Running 1: Reverse Running
Ready	Drive Ready 0: Not Ready 1: Ready
Ctrl from Net	Status of Run command from Network 0: Run command is not from network 1: Run command is from network
Ref from Net	Status of Speed reference from Network 0: Speed reference is not from network 1: Speed reference is from network
At Speed	Speed Agree 0: No Speed Agree 1: Speed actual at speed reference
Drive State	Contains the value from the Control Supervisor (Class 0x29) Instance 1 Attribute 6.
Speed Actual	Actual Drive Speed Monitors drive output frequency. Speed actual data: Output frequency x 2 ^{SS} (SS: Speed scale) Range: 0 to 0xFFFF For example, when output frequency of 1024 with a speed scale of 2: Speed actual data = 1024 x 2 ² = 4096 = 0x1000 Unit depends on o1-03.

10 Web Interface

The web server interface to the option allows management of diagnostic information through a standard web browser. The embedded web pages include:

- Main page (Information)
- Drive Status page (Status, Monitor and Fault History)
- Network Monitor page (Network Monitor)

◆ Main Page (information)

The embedded main page shows basic option information such as vendor ID, serial number, MAC address, and firmware version. This page also shows the status of the option and provides links to the other embedded web pages.

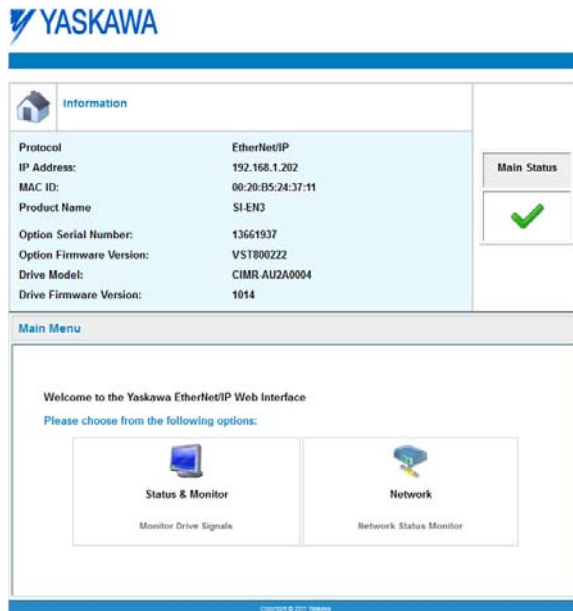

Figure 21 Main Page View

◆ Drive Status Page (Status, Monitor and Fault History)

The embedded drive status page shows basic I/O information and drive state information.

The screenshot displays the YASKAWA web interface for the drive status page. The page title is "Status, Monitor and Fault History". It is divided into several sections:

- Drive Signals:** A summary table showing the status of key drive signals.

Stopped	On	Forward	On	Alarm	Off
Running	Off	Reverse	Off	Fault	Off
- Drive Signals, Multi-function Inputs, and Multi-function Outputs:** A detailed table of drive parameters and terminal statuses.

Drive Signals		Multi-function Inputs		Multi-function Outputs	
Frequency Ref.	0.00 Hz	Terminal S1	Off	Output M1-M2	Off
Output Frequency	0.00 Hz	Terminal S2	Off	Output M3-M4	On
Output Current	0.0 A	Terminal S3	Off	Output M5-M6	Off
DC Bus Voltage	344 VDC	Terminal S4	Off		
Torque Ref.	0.0 %	Terminal S5	Off		
		Terminal S6	Off		
		Terminal S7	Off		
		Terminal S8	Off		
		Terminal S9	NA		
		Terminal S10	NA		
		Terminal S11	NA		
		Terminal S12	NA		
- Analog Input Signals:** A table showing the status of three analog input terminals.

Input Terminal A1	0.0 %
Input Terminal A2	0.0 %
Input Terminal A3	0.0 %
- Fault Information:** A section indicating the current fault status.

Active:	None
---------	------

Copyright © 2011 Yaskawa

Figure 22 Drive Status Page View

◆ Network Monitor Page (Network Monitor)

The embedded network monitor page shows the status of the option network traffic and open I/O connections.

YASKAWA

Network Monitor

Diagnostics

Msg. TX OK	6714	Msg. TX Dropped	0	Msg. TX Errors	0
Msg. Rx OK	10377	Msg. Rx Dropped	0	Msg. RX Errors	0
Current Connections	0	Collisions	0	TX Retry	0

Connection 1

Originator IP Address	0.0.0.0			Time out Multiplier	0
O2T_RPI	0	O2T_API	0	Consume Msg Cnt	0
T2O_RPI	0	T2O_API	0	Produce Msg Cnt	0

Connection 2

Originator IP Address	0.0.0.0			Time out Multiplier	0
O2T_RPI	0	O2T_API	0	Consume Msg Cnt	0
T2O_RPI	0	T2O_API	0	Produce Msg Cnt	0

Copyright © 2011 Yaskawa

Figure 23 Network Monitor Page View

Table 11 Network Monitor Explanations

Network Monitor	Explanation
Msg Tx OK	Cumulative number of messages transmit successfully from the option.
Msg Rx OK	Cumulative number of messages received successfully to the option.
Current Connections	Current number of open connections.
Msg Tx Dropped	Cumulative number of messages dropped due to output network buffer being full and unable to hold the new message.
Msg Rx Dropped	Cumulative number of messages dropped due to input network buffer being full and unable to hold the new message.
Collisions	Cumulative number of collisions.
Msg Tx Errors	Cumulative number of transmit errors.
Msg Rx Errors	Cumulative number of receive errors.
Tx Retry	Cumulative number of transmit errors.
Originator IP Address	The IP address of the network node making this connection.
Time out Multiplier	The value here specifies the multiplier applied to the expected packet rate (API) to obtain the value used by the inactivity timer for this connection.
O2T_RPI	Originator to Target (ie, PLC to SI-EN3/V) Requested Packet Interval for I/O messaging, in milliseconds, for this connection.
O2T_API	Originator to Target (ie, PLC to SI-EN3/V) Actual Packet Interval for I/O messaging, in milliseconds, for this connection.
Consume Msg Cnt	Number of I/O messages consumed (ie, received) from the SI-EN3/V since the connection was established or statistics were reset for this connection.
T20_RPI	Target to Originator (ie, SI-EN3/V to PLC) Requested Packet Interval for I/O messaging, in milliseconds, for this connection.
T20_API	Target to Originator (ie, SI-EN3/V to PLC) Actual Packet Interval for I/O messages, in milliseconds, for this connection.
Produce Msg Cnt	Number of IO messages produced (ie, transmit) from the SI-EN3/V since the connection was established or statistics were reset for this connection.
Reset Statistics Connection1	Clicking this resets the Consume Msg Cnt and the Produce Msg Cnt for this connection to start counting from zero.

Note: Network monitors are reset when the power supply is cycled.

11 Troubleshooting

◆ Drive-Side Error Codes

Drive-side error codes appear on the drive keypad. [Table 12](#) lists causes of the errors and possible corrective actions. Refer to the drive Technical Manual for additional error codes that may appear on the drive digital operator.

■ Faults

Both bUS (option communication error) and EF0 (Option Card External Fault) can appear as an alarm or as a fault. When a fault occurs, the digital operator ALM LED remains lit. When an alarm occurs, the ALM LED flashes.

If communication stops while the drive is running, use the following questions as a guide to help remedy the fault:

- Is the option properly installed?
- Is the communication line properly connected to the option? Is it loose?
- Is the controller program working? Has the controller/PLC CPU stopped?
- Did a momentary power loss interrupt communications?

Table 12 Fault Displays, Causes, and Possible Solutions

Keypad Display		Fault Name
bUS	bUS	Option Communication Error
		<ul style="list-style-type: none"> • After establishing initial communication, the connection was lost. • Only detected when the run command or frequency reference is assigned to the option (b1-01 = 3 or b1-02 = 3).
Cause		Possible Solution
No signal was received from the PLC.	Faulty communications wiring	<ul style="list-style-type: none"> • Check for faulty wiring. • Correct any wiring problems.
An existing short circuit or communications disconnection		
A data error occurred due to electric interference.		<ul style="list-style-type: none"> • Counteract noise in the control circuit, main circuit, and ground wiring. • If a magnetic contactor is identified as a source of noise, install a surge absorber to the contactor coil. • Use only recommended cables or other shielded line. Ground the shield on the controller side or the drive input power side. • Separate all communication wiring from drive power lines. Install an EMC noise filter to the drive power supply input. • Counteract noise in the master controller (PLC).

11 Troubleshooting

The option is not properly connected to the drive.	Reinstall the option.
Option is damaged	If there are no problems with the wiring and the error continues to occur, replace the option.
Connection Time-out	<ul style="list-style-type: none"> The option Requested Packet Interval (RPI) timer timed out. Make sure that RPI time is set properly.
Duplicate IP Address	Check if the option shares IP Address with at least one other node. Check the setting values of F7-01 to F7-04 (IP Address).

Keypad Display		Fault Name
	EF0	Option Card External Fault
		The alarm function for an external device has been triggered.
Cause		Corrective Action
An external fault was received from the PLC.		<ol style="list-style-type: none"> Remove the cause of the external fault. Reset the external fault input from the PLC.
Problem with the PLC program		Check the PLC program.
PLC is in the Idle Mode.		<ol style="list-style-type: none"> Set the PLC to the Run Mode. Set the parameter F6-54 = 0 (Enabled) to ignore errors while the PLC is in the Idle Mode.

Keypad Display		Fault Name
	oFA00	Option Card Fault
		Option is not properly connected.
Cause		Possible Solution
The option card installed into port CN5-A is incompatible with the drive.		Connect the option to the correct option port. Note: PG option cards are supported by option ports CN5-B and CN5-C only.

Keypad Display		Fault Name
	oFA01	Option Card Fault
		Option is not properly connected.
Cause		Possible Solution
The option connected to option port CN5-A was changed during run.		De-energize the drive and plug the option into the drive according to Installation Procedure on page 18 .

Keypad Display		Fault Name
oFA03	oFA03	Option Card Fault
		Option self-diagnostics error.
Cause		Possible Solution
The option card connection to port CNS-A is faulty.		<ol style="list-style-type: none"> 1. Turn off the power. 2. Check if the option is properly plugged into the option port. 3. Replace the option if the fault continues to occur.

Keypad Display		Fault Name
oFA04	oFA04	Option Card Fault
		Option flash write mode.
Cause		Possible Solution
The option card connection to port CNS-A is faulty.		<ol style="list-style-type: none"> 1. Turn off the power. 2. Check if the option is properly plugged into the option port. 3. Replace the option if the fault continues to occur.

Keypad Display		Fault Name
oFA30 to oFA43	oFA30 to oFA43	Option Card Fault
		Communication ID error.
Cause		Possible Solution
The option card connection to port CNS-A is faulty.		<ol style="list-style-type: none"> 1. Turn off the power. 2. Check if the option is properly plugged into the option port. 3. Replace the option if the fault continues to occur.

11 Troubleshooting

■ Minor Faults and Alarms

Keypad Display		Minor Fault Name	
CALL	CALL	Serial communication transmission error	
		Communication is not established.	
Cause		Possible Solution	Minor Fault (H2-□□ = 10)
Communication wiring is faulty.		<ul style="list-style-type: none"> • Check for wiring errors. • Correct the wiring. 	YES
An existing short circuit or communications disconnection		Check disconnected cables and short circuits and repair as needed.	
Programming error on the master side.		Check communications at start-up and correct programming errors.	
Communication circuitry is damaged.		<ul style="list-style-type: none"> • Perform a self-diagnostics check • If the problem continues, replace either the control board or the entire drive. For instructions on replacing the control board, contact Yaskawa or your nearest sales representative. 	
Termination resistor of the MEMOBUS/Modbus communications is not enabled.		Set DIP switch S2 to the ON position to enable the termination resistor on a drive located at the end of a network line.	

■ Explicit Message Communications Errors

When there is a problem with a request message sent from the master in explicit communications, the drive will return one of the following error codes.

Error Code (hex)	Description	Cause	Possible Solution
08	Service not supported	The service code is incorrect.	Correct the service code.
09	Invalid attribute value	The attribute is incorrect.	Correct the attribute.
0C	Object state conflict	Attempted to change an drive constant that cannot be changed while the drive is running.	Stop the drive.
0E	Attribute not settable	Attempted to change a read-only attribute.	Correct the service code or attribute setting.
13	Not enough data	The data size is incorrect.	Correct the data size.
14	Attribute not supported	Attempted to execute a service not defined for the attribute.	Correct the service code or attribute setting.
15	Too much data	The data size is incorrect.	Correct the data size.
16	Object does not exist	An unsupported object was specified.	Correct the class or instance setting.
1F	Vendor-specific error	<ul style="list-style-type: none"> Attempted to change a drive constant that cannot be changed while the drive is running. Attempted to change a drive constant to a value outside the setting range. 	<ul style="list-style-type: none"> Stop the drive. Specify a value within the setting range.
20	Invalid parameter	Attempted to change to a data value outside the setting range.	Specify a data value within the setting range.

Note: Refer to the MEMOBUS/Modbus Data Table in the MEMOBUS/Modbus Communications chapter of the drive manual for a list of monitor data using the MEMOBUS/Modbus message area.

11 Troubleshooting

◆ Option Error Codes

■ Option Fault Monitors U6-98 and U6-99

The option can declare error/warning conditions via drive monitor parameters on the drive digital operator as shown in [Table 13](#).

Table 13 Option Fault Monitor Descriptions

Fault Condition	Fault Declared	Status Value (U6-98/U6-99)	Description
No Fault	n/a	0	No faults.
Force Fault	EF0	3	Network sent a message to force this node to the fault state.
Network Link Down	BUS ERROR	1100	No network link to option.
Connection Time-out	BUS ERROR	1101	The node timer (Requested Packet Interval) timed out.
Duplicate IP Address	BUS ERROR	1102	This node and at least one other node have the same IP Address.
Default MAC Address	None	1103	Factory default MAC Address programmed into the option. Return for reprogramming.

Two drive monitor parameters, U6-98 and U6-99 assist the user in network troubleshooting.

- U6-98 displays the first declared fault since the last power cycle. U6-98 is only cleared upon drive power-up.
- U6-99 displays the present option status. U6-99 is cleared upon a network-issued fault reset and upon power-up.

If another fault occurs while the original fault is still active, parameter U6-98 retains the original fault value and U6-99 stores the new fault status value.

12 European Standards



Figure 24 CE Mark

The CE mark indicates compliance with European safety and environmental regulations. It is required for engaging in business and commerce in Europe.

European standards include the Machinery Directive for machine manufacturers, the Low Voltage Directive for electronics manufacturers, and the EMC guidelines for controlling noise.

This option displays the CE mark based on the EMC guidelines.

EMC Guidelines: 2014/30/EU

Drives used in combination with this option and devices used in combination with the drive must also be CE certified and display the CE mark. When using drives displaying the CE mark in combination with other devices, it is ultimately the responsibility of the user to ensure compliance with CE standards. Verify that conditions meet European standards after setting up the device.

◆ **EMC Guidelines Compliance**

This drive is tested according to European standards EN 61800-3:2004+A1:2012 and complies with EMC guidelines. The CE marking is declared based on the harmonized standards.

■ **EMC Guidelines Installation Conditions**

Verify the following installation conditions to ensure that other devices and machinery used in combination with this option also comply with EMC guidelines:

1. Use dedicated shield cable for the option and external device (encoder, I/O device, master), or run the wiring through a metal conduit.
2. Keep wiring as short as possible and ground the largest possible surface area of the shield to the metal panel according to [Figure 26](#).

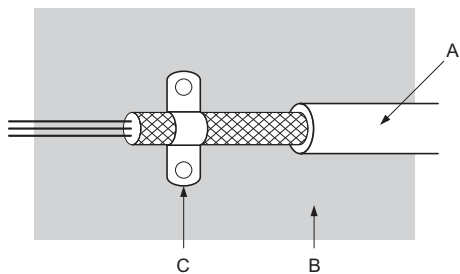

A – Braided shield cable

C – Cable clamp (conductive)

B – Metal panel

Figure 25 Ground Area

■ EMC Filter and Option Installation for CE Compliance

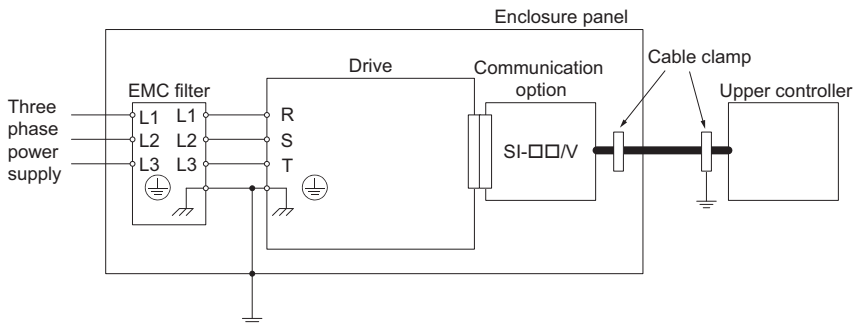

Figure 26 EMC Filter and Option Installation for CE Compliance

13 Specifications

Table 14 Option Specifications

Item	Specification
Model	SI-EN3/V
Supported Messages	Explicit: Explicit Class 3, Unconnected I/O: Class 1, Listen Only, Input Only
I/O Assembly Instance	Input: 8 types (4 to 44 Bytes) Output: 8 types (4 to 44 Bytes)
SI-EN3/V Specification	Conformance Level A5: Passed
SI-EN3/V Profile	AC Drive
Connector Type	RJ45 8-pin Straight Connector STP Cat5e cable
Physical Layer Type	Isolated Physical Layer TCP Protocol Transformer Isolated
IP Address Setting	Programmable from drive keypad or network
Communication Speed	Programmable from drive keypad or network: 10/100 Mbps, auto-negotiate
Number of Connections	I/O: 2 Explicit: 6
Duplex Mode	Half-forced, Auto-negotiate, Full-forced
Address Startup Mode	Static, BOOTP, DHCP
Ambient Temperature	-10°C to +50°C (14°F to 122°F)
Humidity	95% RH or lower with no condensation
Storage Temperature	-20°C to +60°C (-4°F to 104°F) allowed for short-term transport of the product
Area of Use	Indoors and free from: <ul style="list-style-type: none"> • Oil mist, corrosive gas, flammable gas, and dust • Radioactive materials or flammable materials, including wood • Harmful gas or fluids • Salt • Direct sunlight • Falling foreign objects
Altitude	1000 m (3280 ft.) or lower

13 Specifications

◆ Revision History

The revision dates and the numbers of the revised manuals appear on the bottom of the back cover.

MANUAL NO.

TOBP C730600 60B <1>

Revision number

Published in Japan April 2014

Date of publication

Date of Publication	Revision Number	Section	Revised Content
July 2017	<2>	Front cover	Revision: Format
		All	Revision: Reviewed and corrected entire documentation.
		Chapter 2	Addition: Note in Table 1
		Back cover	Revision: Address, format
April 2014	<1>	All	Revision: Reviewed and corrected entire documentation.
		Chapter 7	Addition: Information on assemblies 115 and 155.
		Chapter 12	Addition: European Standards
		Back cover	Revision: Address
March 2012	–	–	First edition

YASKAWA AC Drive-V1000 Option EtherNet/IP Installation Manual

DRIVE CENTER (INVERTER PLANT)

2-13-1, Nishimiyachi, Yakuhashi, Fukuoka, 824-8511, Japan
Phone: +81-930-25-2548 Fax: +81-930-25-3431
<http://www.yaskawa.co.jp>

YASKAWA ELECTRIC CORPORATION

New Pier Takeshiba South Tower, 1-16-1, Kaigan, Minatoku, Tokyo, 105-6891, Japan
Phone: +81-3-5402-4502 Fax: +81-3-5402-4580
<http://www.yaskawa.co.jp>

YASKAWA AMERICA, INC.

2121, Norman Drive South, Waukegan, IL 60085, U.S.A.
Phone: +1-800-YASKAWA (927-5292) or +1-847-887-7000 Fax: +1-847-887-7310
<http://www.yaskawa.com>

YASKAWA ELÉTRICO DO BRASIL LTDA.

777, Avenida Piraporinha, Diadema, São Paulo, 09950-000, Brasil
Phone: +55-11-3585-1100 Fax: +55-11-3585-1187
<http://www.yaskawa.com.br>

YASKAWA EUROPE GmbH

Hauptstraße 185, 65760 Eschborn, Germany
Phone: +49-6196-569-300 Fax: +49-6196-569-398
<http://www.yaskawa.eu.com> E-mail: info@yaskawa.eu.com

YASKAWA ELECTRIC KOREA CORPORATION

35F, Three IFC, 10 Gukjegeumyung-ro, Yeongdeungpo-gu, Seoul, 07326, Korea
Phone: +82-2-784-7844 Fax: +82-2-784-8495
<http://www.yaskawa.co.kr>

YASKAWA ELECTRIC (SINGAPORE) PTE. LTD.

151, Lorong Chuan, #04-02A, New Tech Park, 556741, Singapore
Phone: +65-6282-3003 Fax: +65-6289-3003
<http://www.yaskawa.com.sg>

YASKAWA ELECTRIC (THAILAND) CO., LTD.

59, 1st-5th Floor, Flourish Building, Soi Ratchadapisek 18, Ratchadapisek Road, Huaykwang, Bangkok, 10310, Thailand
Phone: +66-2-017-0099 Fax: +66-2-017-0799
<http://www.yaskawa.co.th>

YASKAWA ELECTRIC (CHINA) CO., LTD.

22F, One Corporate Avenue, No.222, Hubin Road, Shanghai, 200021, China
Phone: +86-21-5385-2200 Fax: +86-21-5385-3299
<http://www.yaskawa.com.cn>

YASKAWA ELECTRIC (CHINA) CO., LTD. BEIJING OFFICE

Room 1011, Tower W3 Oriental Plaza, No. 1, East Chang An Ave.,
Dong Cheng District, Beijing, 100738, China
Phone: +86-10-8518-4086 Fax: +86-10-8518-4082

YASKAWA ELECTRIC TAIWAN CORPORATION

12F, No. 207, Sec. 3, Beishin Rd., Shindian Dist., New Taipei City 23143, Taiwan
Phone: +886-2-8913-1333 Fax: +886-2-8913-1513 or +886-2-8913-1519
<http://www.yaskawa.com.tw>

YASKAWA INDIA PRIVATE LIMITED

#17/A, Electronics City, Hosur Road, Bangalore, 560 100 (Karnataka), India
Phone: +91-80-4244-1900 Fax: +91-80-4244-1901
<http://www.yaskawaindia.in>

YASKAWA

YASKAWA ELECTRIC CORPORATION

In the event that the end user of this product is to be the military and said product is to be employed in any weapons systems or the manufacture thereof, the export will fall under the relevant regulations as stipulated in the Foreign Exchange and Foreign Trade Regulations. Therefore, be sure to follow all procedures and submit all relevant documentation according to any and all rules, regulations and laws that may apply.
Specifications are subject to change without notice for ongoing product modifications and improvements.

© 2012 YASKAWA ELECTRIC CORPORATION

MANUAL NO.

TOBP C730600 60C <2>

Published in Japan July 2017

17-4-18